 OTIF	ROLLING STOCK FREIGHT WAGONS – ANNEX A			UTP WAG - A Page 1 of 6
Status: preDRAFT	Version: 01	Ref.: A 94-02A/1.2010	Original: EN	Date: 26.02.2010

APTU Uniform Rules (Appendix F to COTIF 1999)

**Uniform Technical Prescriptions (UTP) applicable to
Rolling Stock, subsystem**

FREIGHT WAGONS - (UTP WAG) - ANNEX A

STRUCTURES AND MECHANICAL PARTS

 OTIF	ROLLING STOCK FREIGHT WAGONS – ANNEX A		UTP WAG - A Page 2 of 6	
	Status: preDRAFT	Version: 01	Ref.: A 94-02-A/1.2010	Original: EN

Explanatory note:

The texts of this UTP which appear without columns are identical with corresponding texts of the European Community regulations. Texts which appear in two columns differ; left-hand column contains the UTP regulations, right-hand column shows the text in the corresponding EC regulations. The text in the right hand column is for information only and not part of the OTIF regulations.

OTIF UTP

Corresponding text in EC regulations ¹

EC
ref. ²

STRUCTURES AND MECHANICAL PARTS

A.1 BUFFERS

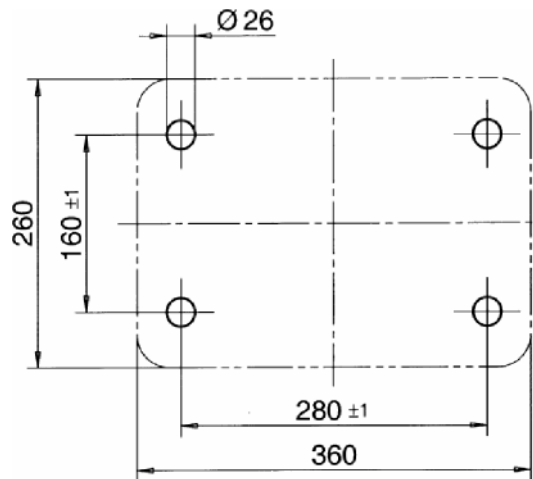

Fig. A1 Buffer supporting plate

¹ TSI Freight Wagons – The Annex to the Commission Decision 2006/861/EC published in the EU Official Journal L344 on 08.12.2006 as amended by Commission Decision 2009/107/EC published in EU Official Journal L45 on 14.02.2009.

² If no EC reference is indicated, it means that the chapter/section number is the same as in the OTIF text.



OTIF

ROLLING STOCK
FREIGHT WAGONS – ANNEX A

UTP WAG - A
Page 3 of 6

Status: **preDRAFT**

Version: 01

Ref.: A 94-02-A/1.2010

Original: EN

Date: 26.02.2010

OTIF UTP

Corresponding text in EC regulations ¹

EC
ref. ²

A.2 DRAW GEAR

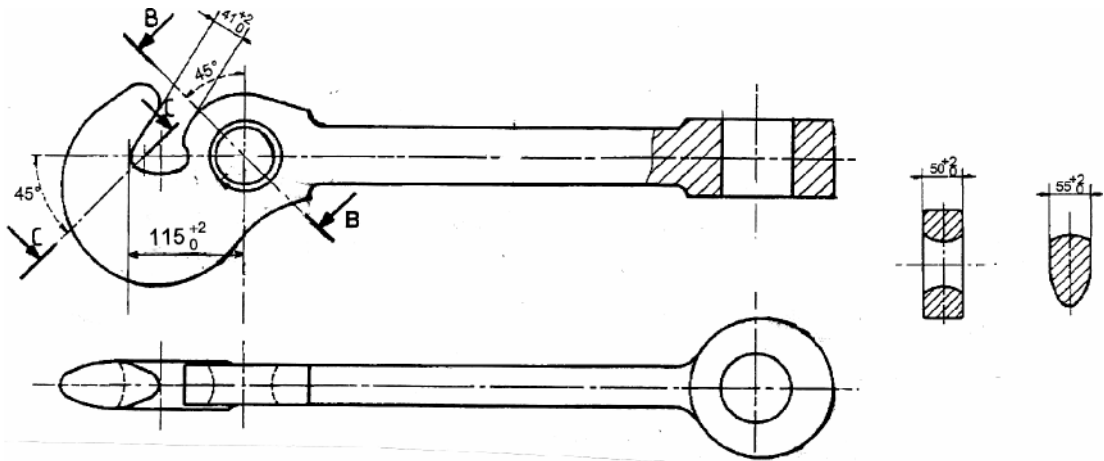

Fig. A2 Draw hook – dimensions

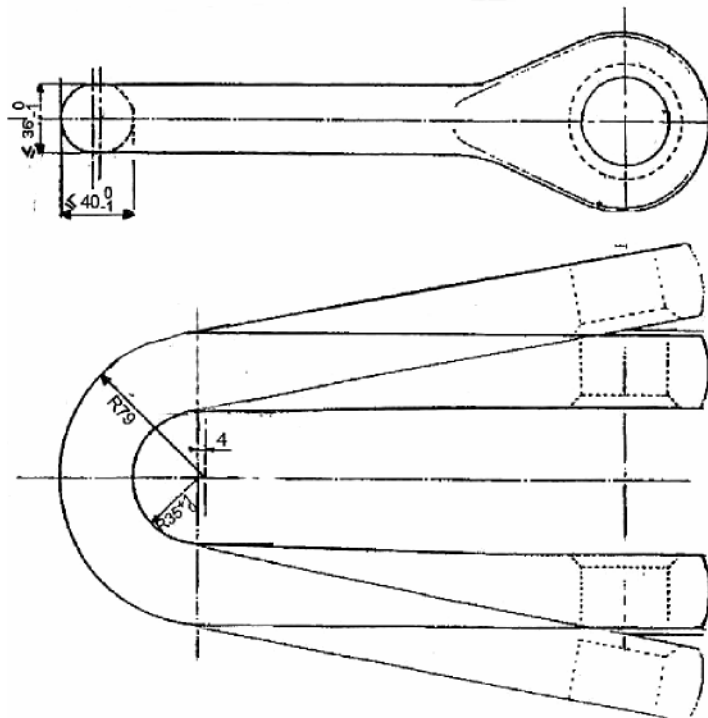

Fig. A3 D-shackle for screw coupler



OTIF

**ROLLING STOCK
FREIGHT WAGONS – ANNEX A**

UTP WAG - A
Page 4 of 6

Status: **preDRAFT**

Version: 01

Ref.: A 94-02-A/1.2010

Original: EN

Date: 26.02.2010

OTIF UTP

Corresponding text in EC regulations ¹

EC
ref. ²

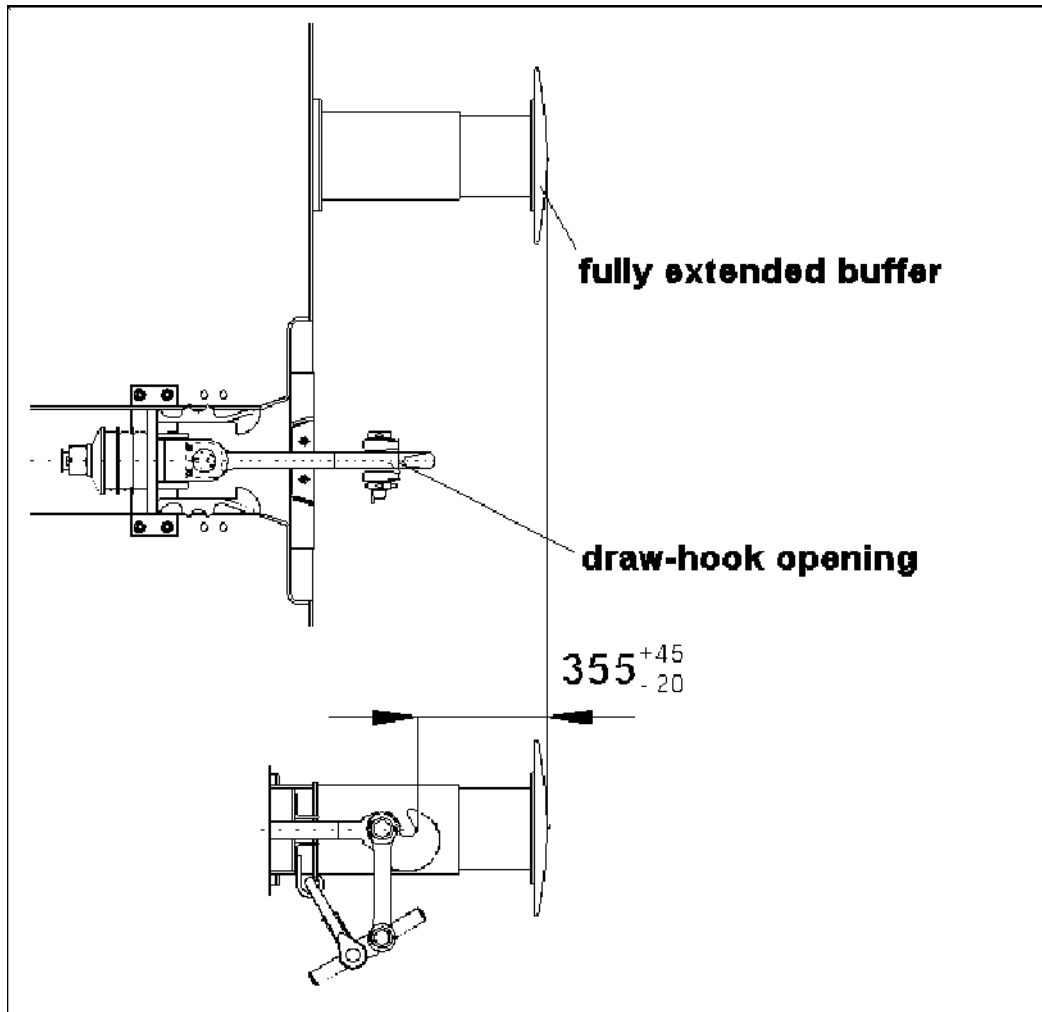

Fig. A4 Draw- and buffing gear



OTIF

ROLLING STOCK
FREIGHT WAGONS – ANNEX A

UTP WAG - A
Page 5 of 6

Status: **preDRAFT**

Version: 01

Ref.: A 94-02-A/1.2010

Original: EN

Date: 26.02.2010

OTIF UTP

Corresponding text in EC regulations ¹

EC
ref. ²

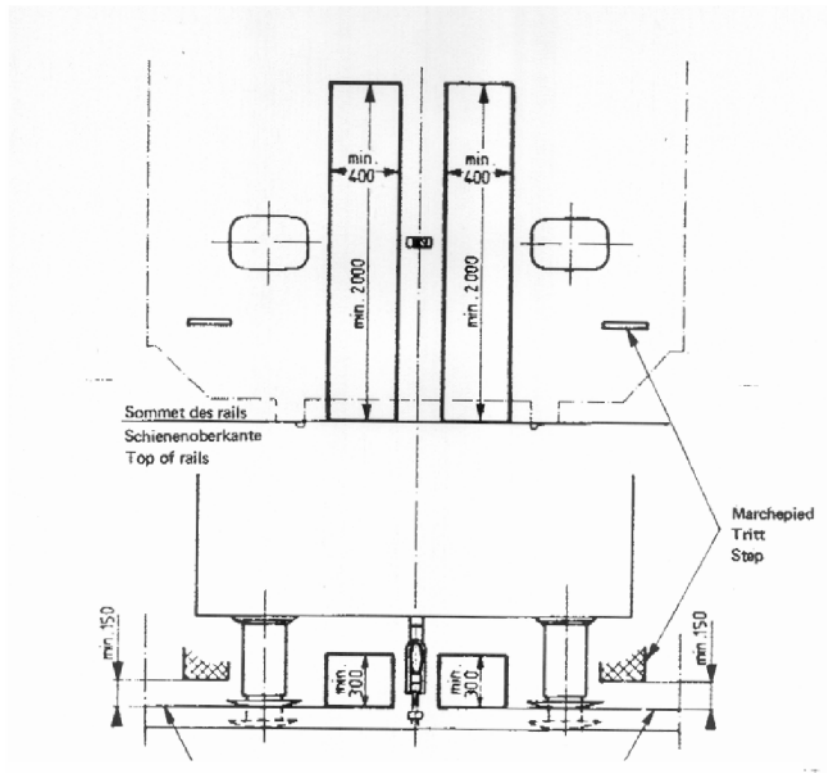
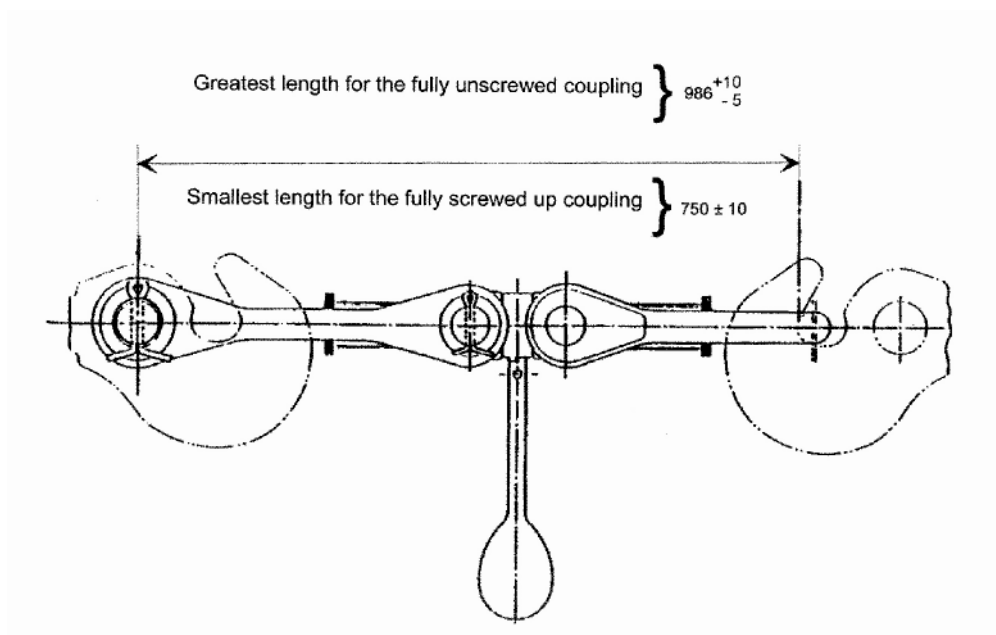



Fig. A5 Berne rectangle

CLEARANCES TO BE PROVIDED AT VEHICLE EXTREMITIES
 ESPACES LIBRES A RESERVER AUX EXTREMITES DES VEHICULES
 FREIZUHALTENDE RÄUME AN DEN WAGENENDEN



 OTIF	ROLLING STOCK FREIGHT WAGONS – ANNEX A		UTP WAG - A Page 6 of 6	
	Status: preDRAFT	Version: 01	Ref.: A 94-02-A/1.2010	Original: EN

OTIF UTP

Corresponding text in EC regulations ¹

EC
ref. ²

Fig. A6 Screw coupler and draw hooks

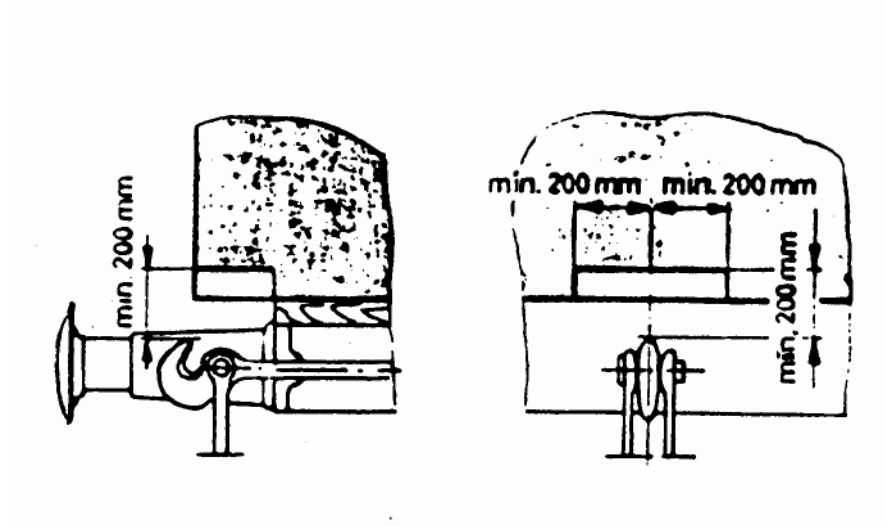

Fig. A7 Clearance to be provided at wagon extremities above the draw hook