

|   |  |                         |                              |                  |
|---|--|-------------------------|------------------------------|------------------|
|  <b>OTIF</b> | <b>ROLLING STOCK<br/>FREIGHT WAGONS – ANNEX YY</b> |                         | UTP WAG - YY<br>Page 1 of 18 |                  |
| Status: <b>PROPOSAL</b>   | Version: 01  | Ref.: A 94-02-YY/2.2011 | Original: EN                 | Date: 11.07.2011 |

APTU Uniform Rules (Appendix F to COTIF 1999)

**Uniform Technical Prescriptions (UTP) applicable to  
Rolling Stock, subsystem**

**FREIGHT WAGONS - (UTP WAG) - ANNEX YY**

**STRUCTURES AND MECHANICAL PARTS**

**STRENGTH REQUIREMENTS FOR CERTAIN TYPES OF  
WAGON COMPONENTS**

|   |  |             |                                      |              |
|---|--|-------------|--------------------------------------|--------------|
|  <b>OTIF</b> | <b>ROLLING STOCK<br/>FREIGHT WAGONS – ANNEX YY</b> |             | <b>UTP WAG - YY<br/>Page 2 of 18</b> |              |
|   | Status: <b>PROPOSAL</b>                            | Version: 01 | Ref.: A 94-02-YY/2.2011              | Original: EN |

Explanatory note:

The texts of this UTP which appear without columns are identical with corresponding texts of the European Union regulations. Texts which appear in two columns differ; left-hand column contains the UTP regulations, right-hand column shows the text in the corresponding EU regulations. The text in the right hand column is for information only and not part of the OTIF regulations.

OTIF UTP

| Corresponding text in EU regulations<sup>1</sup>

EU ref.<sup>2</sup>

## YY.1 INTRODUCTION

This appendix provides the requirements for the design of wagon components and load restraint systems applicable to types of wagon in general use. The requirements shall be applied only where they are appropriate to the intended application.

## YY.2 STRENGTH OF WAGON BODY STRUCTURES

### YY.2.1 Stresses due to the vertical load

For the vertical load case, the loads on the vehicle must be distributed:

- over a width of 2 m,
- in the case of open bogie wagons and open bogie flat wagons, over a width of 1,2 m,
- over the whole width of the floor,

according to which gives the more unfavourable stresses in the underframe.

The maximum deflection of the underframe under the applied load should not exceed 3 ‰ of the wheelbase or of the bogie pivot pitch from the initial position (including the effects of any counter-deflection).

### YY.2.2 Combined stresses

For certain types of wagons, such as those with offset/depressed decks, it is particularly important to consider the combination of the stresses due to horizontal and vertical loading.

Tank wagons designed for the transport of pressurised products must be designed to withstand, without sustaining residual damage, both the load corresponding to the maximum permissible load capacity and that resulting from the maximum working pressure (as defined by the RID) for which the tank has to be designed.

### YY.2.3 Strength of the wagon floor to support industrial trucks and road vehicles (1).

The wagon floor should be capable of withstanding the following loads without suffering any residual deformation:

- By industrial trucks:
  - Simultaneous loading of each of the two front wheels of the truck with 30 kN;
  - Bearing surface of a wheel 220 cm<sup>2</sup> for a width of about 150 mm;
  - Average mean distance between the front wheels of the industrial truck 650 mm.
- By road vehicles (only with flat wagons and mixed open/flat wagons):
  - Loading with 65 kN per twin carrying wheel,
  - Bearing surface of a twin carrying wheel of 700 cm<sup>2</sup> for a wheel width of about 200 mm.

Note: Repetitive loads of this nature may need to be considered as fatigue load cases.

(1) Determination of the strength of freight wagon timber floors is the purpose of section 3A of ERRI Report B 12/DT 135 'Allgemein anwendbare Berechnungsmethoden für die Entwicklung neuer Güterwagenbauarten oder Güterwagendrehgestelle' (Generally applicable calculation

<sup>1</sup> TSI Freight Wagons – The Annex to the Commission Decision 2006/861/EC published in the EU Official Journal L344 on 08.12.2006 as amended by Commission Decision 2009/107/EC published in EU Official Journal L45 on 14.02.2009.

<sup>2</sup> If no EU reference is indicated, it means that the chapter/section number is the same as in the OTIF text.

|   |  |             |                                      |              |
|---|--|-------------|--------------------------------------|--------------|
|  <b>OTIF</b> | <b>ROLLING STOCK<br/>FREIGHT WAGONS – ANNEX YY</b> |             | <b>UTP WAG - YY<br/>Page 3 of 18</b> |              |
|   | Status: <b>PROPOSAL</b>                            | Version: 01 | Ref.: A 94-02-YY/2.2011              | Original: EN |

OTIF UTP

Corresponding text in EU regulations<sup>1</sup>

EU ref.<sup>2</sup>

methods for the development of goods new types of goods wagons or goods wagon bogies). This Technical Document contains details about the design of floors for new wagons. Tests need not be carried out if the floors correspond to the provisions of ERRI B 12/DT 135.

## YY.3 COVERED WAGONS WITH FIXED ROOF AND FIXED OR MOVING SIDE-WALLS AND COVERED WAGONS WITH SLIDING ROOFS

### YY.3.1 Strength of fixed side and end-walls

At a height of 1 m above the floor the walls should sustain the forces defined below (acting from the inside out). In the case of refrigerator vans, the characteristics of the material from which the inner skin and the insulation are made should be taken into account. There are four loading cases:

- transverse force applied to all side uprights;
- longitudinal force applied to all end posts;
- in the case of metal walls, transverse force acting on a point in the side-wall at the ventilation opening and along its centre-line;
- in the case of metal walls, longitudinal force acting along the centre-line of the end-wall.

| Load case | Minimum Design Load — kN | Permissible Permanent Deformation — mm |
|-----------|--------------------------|--|
| a         | 8                        | 2                                      |
| b         | 40                       | 1                                      |
| c         | 10                       | 3                                      |
| d         | 18                       | 2                                      |

For load cases c) and d) above the loaded area shall be 100 x 100 mm

Note: Walls made of wooden panels should sustain the same loads as metal walls and the panels should be manufactured in a manner that ensures a consistent quality and performance.

### YY.3.2 Strength of side doors

#### Sliding doors (single and two-leafed)

Transverse loading

The door(s) in closed position and locked, should sustain a horizontal normal force from the inside of the wagon outwards, representing the forces produced by a shift in the load as well as by pressure differences resulting from the high-speed passing of passenger trains in tunnels. This force is applied in the following conditions:

- at the centre of the door a force of 8 kN applied over a 1x1 m area;
- at each connection/attachment point a force of 5 kN applied over 300x300 mm area.

No permanent deformation or loss of functionality should occur, either on the door itself (wall and framework) or on the locking, sliding or guiding components as a result of these loads.

### YY.3.3 Strength of sliding walls

The sliding walls, closed and locked, should resist a horizontal cross force applied from the inside of the wagon outwards. This force represents the forces produced by a shift of the load as well as by pressure differences resulting from the highspeed passing of passenger trains in tunnels. The load cases are as follows:

- Sliding walls which are less than 2,5 m long should meet the same load cases as sliding doors;
- Sliding walls from 2,5 m to 5 m long should have a 20 kN load applied at mid-wall

|   |  |             |                                     |              |
|---|--|-------------|-------------------------------------|--------------|
|  <b>OTIF</b> | <b>ROLLING STOCK<br/>FREIGHT WAGONS – ANNEX YY</b> |             | <b>UTP WAG - YY</b><br>Page 4 of 18 |              |
|   | Status: <b>PROPOSAL</b>                            | Version: 01 | Ref.: A 94-02-YY/2.2011             | Original: EN |

OTIF UTP

| Corresponding text in EU regulations<sup>1</sup>

EU ref.<sup>2</sup>

over a 1x1 m area.

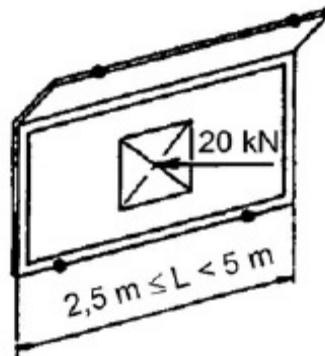

- c) Sliding walls over  $5\text{ m} < L < 7\text{ m}$  long should have a 15 kN load applied in each case at a distance of  $1/4$  of the sliding wall length from the end of the sliding wall and at a height of 1 m over a 1x1 m area.

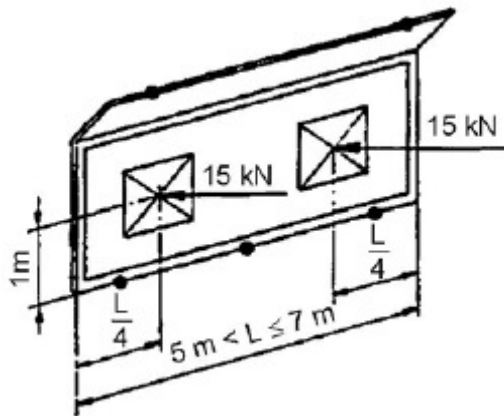

- d) Sliding walls over 7 m long should have a 20 kN load applied in each case at a distance of  $1/4$  of the length of the sliding wall from the end of the sliding wall and at a height of 1 m over a 1x1 m area.

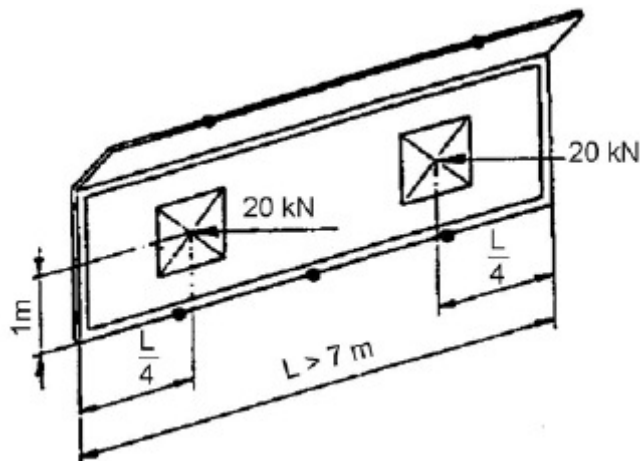

Plus the application of a 10 kN load on the lower flange of a sliding wall between two connection/attachment points immediately above floor level, over an area: 200 mm high by 300 mm wide.

|   |  |             |                                     |              |
|---|--|-------------|-------------------------------------|--------------|
|  <b>OTIF</b> | <b>ROLLING STOCK<br/>FREIGHT WAGONS – ANNEX YY</b> |             | <b>UTP WAG - YY</b><br>Page 5 of 18 |              |
|   | Status: <b>PROPOSAL</b>                            | Version: 01 | Ref.: A 94-02-YY/2.2011             | Original: EN |

OTIF UTP

| Corresponding text in EU regulations <sup>1</sup>

EU ref. <sup>2</sup>

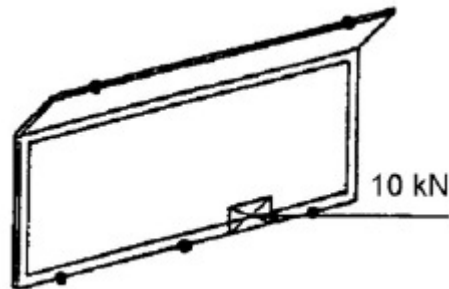

#### YY.3.4 Forces resulting from the passing of trains

Individual strength requirements for the outside connection/attachment points of the sliding wall (front surface over an area 200 mm high and 300 mm wide):

- with two-axled wagons and with bogie wagons with more than 2 sliding walls per side; force = 11,5 kN
- with bogie wagons with 2 sliding walls per side; force = 14 kN.

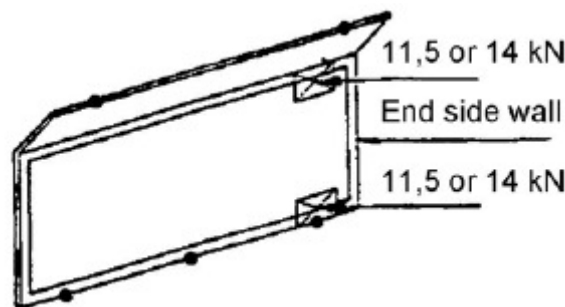

The point of application should be immediately above the floor and, in the roof area, as close as possible to the upper connection/attachment point. It is permissible for the upper load to be applied to the vertical section of the sliding wall.

No permanent visible deformation or deterioration of the elements for closing, rolling and guiding the wall should result from the application of the above loads. It must be possible to move the panels without difficulty. A permanent deformation, equal at most to half the distance between the inner face of an opened wall and the maximum projecting point of a closed wall, is permissible.

#### YY.3.5 Strength of lockable partitions of sliding-wall wagons

When the partition is locked a force which corresponds to a buffing impact of 5 t at a speed of 13 km/h and which simulates the stresses produced by a palletised load should be applied to a square surface area of 1x1 m, 600 mm and 1100 mm above the top of the floor. The forces and deformation of the partition are to be measured. The deformation should not cause the partition to become detached or cause damage to the locking mechanism.

A force of 50 kN should be applied to the seat of the lower lock over an area measuring 100 x 100 mm. There must be no damage and no permanent deformation as a result of the load.

#### YY.3.6 Strength of roof

The roof must be able to withstand a force of 1 kN applied from outside inwards to a surface area of 200 cm<sup>2</sup> without any notable deformation.

In addition, sliding roofs must withstand a vertical force from the inside outwards of 4,5 kN per connection/attachment point applied over a 300x300 mm square area. No deterioration or permanent deformation of the elements for closing, rolling and guiding the sliding roofs should result from this load.

|   |  |             |                                      |              |
|---|--|-------------|--------------------------------------|--------------|
|  <b>OTIF</b> | <b>ROLLING STOCK<br/>FREIGHT WAGONS – ANNEX YY</b> |             | <b>UTP WAG - YY<br/>Page 6 of 18</b> |              |
|   | Status: <b>PROPOSAL</b>                            | Version: 01 | Ref.: A 94-02-YY/2.2011              | Original: EN |

OTIF UTP

| Corresponding text in EU regulations <sup>1</sup>

EU ref. <sup>2</sup>

## **YY.4 WAGONS WITH FULL OPENING ROOF (ROLLER ROOF AND HINGED ROOF)**

### **YY.4.1 Wagons for the transport of heavy part-load goods**

#### **Strength of side-walls**

The side-walls should withstand a total force of 30 kN applied at the 4 door pillars, 1,5 m above the floor. Where applicable, the elastic deformation of the upper wall member should be lower than the derailing limit of the roof. After removal of the load, the roof should be in perfect working order.

#### **Strength of side-wall door**

The standard door requirements, YY.3.2, should be met.

#### **Strength of roof**

Where it is foreseeable that a person might walk on it, the roof should withstand the weight of a person walking over it. It should be able to take a force of 1 kN at the most unfavourable point on an area of 300 x 300 mm.

### **YY.4.2 Wagons for the transport of heavy bulk goods**

#### **Strength of side-walls**

According to YY.4.1.

#### **Strength of side-wall door**

According to YY.3.2.

#### **Strength of roof**

According to YY.3.6.

## **YY.5 HIGH-SIDED OPEN WAGONS**

### **YY.5.1 Resistance of side-walls to transverse forces and of the edges of side and end rails to impacts**

The following load cases apply, acting outwards in the horizontal direction at a level of 1,5 m above the floor:

- a force of 100 kN applied at four centre posts of each side-wall, as indicated below;
- a force of 40 kN applied at the corner posts of wagons equipped with drop ends;
- 25 kN at the middle of the upper side-wall rails;
- 60 kN at the middle of the upper rail of the end swing doors, for wagons equipped with these.

Note: For the tests a) and b), the stipulated forces should be applied twice successively and only the deformations measured during the second load application should be taken into account.

The permanent deformation at the point where the force is applied should not exceed 1 mm. In addition, the elastic deformation should not result in any encroachment of the loading gauge.

#### **Local deformation tests**

Denting tests should be performed on the upper rails of the side-walls by applying a vertical force of 40 kN, as indicated below. The permanent deformation at the point where the force is applied should not exceed 2 mm.

|   |  |             |                                     |              |
|---|--|-------------|-------------------------------------|--------------|
|  <b>OTIF</b> | <b>ROLLING STOCK<br/>FREIGHT WAGONS – ANNEX YY</b> |             | <b>UTP WAG - YY</b><br>Page 7 of 18 |              |
|   | Status: <b>PROPOSAL</b>                            | Version: 01 | Ref.: A 94-02-YY/2.2011             | Original: EN |

OTIF UTP

Corresponding text in EU regulations<sup>1</sup>

EU ref.<sup>2</sup>

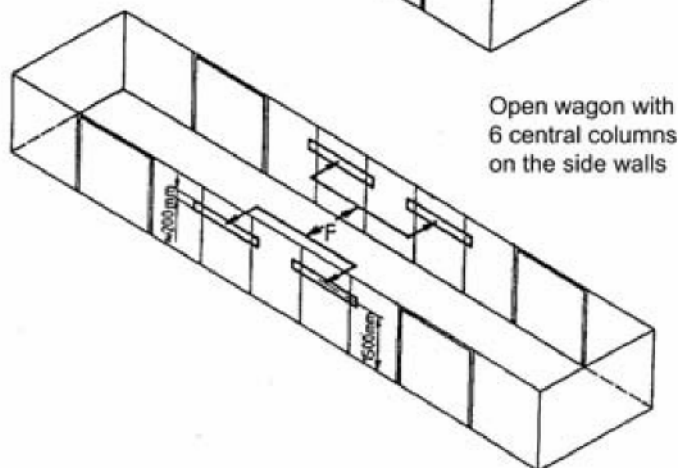
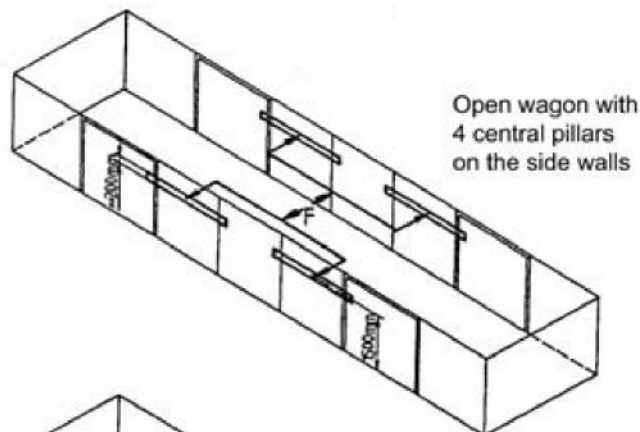
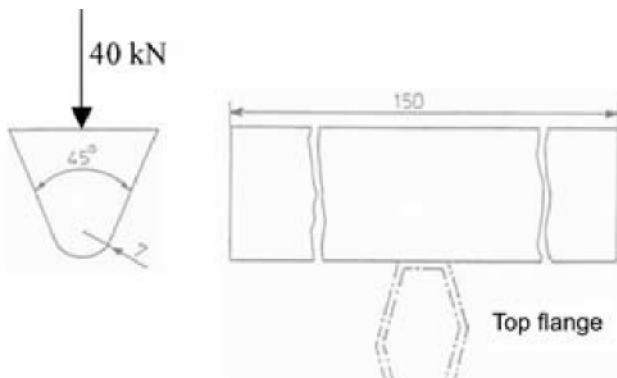

### YY.5.2 Strength of the side doors

A horizontal force of 20 kN should be applied at a the height of the door locking bar or 1 m above the floor and on the centre-line of the opening. The permanent deformation must not exceed 1 mm on the door itself, and no deterioration or permanent deformation of the bridges or closing elements should result.

## YY.6 FLAT WAGONS AND COMPOSITE FLAT/HIGH-SIDED WAGONS

### YY.6.1 Strength of the side and end flaps

The requirement is to carry the load due to a lorry loaded to 65 kN per twin carrying wheel bearing on a total surface of 700 cm<sup>2</sup> {width of wheel about 200 mm} on the flaps

|   |  |             |                                      |              |
|---|--|-------------|--------------------------------------|--------------|
|  <b>OTIF</b> | <b>ROLLING STOCK<br/>FREIGHT WAGONS – ANNEX YY</b> |             | <b>UTP WAG - YY<br/>Page 8 of 18</b> |              |
|   | Status: <b>PROPOSAL</b>                            | Version: 01 | Ref.: A 94-02-YY/2.2011              | Original: EN |

OTIF UTP

Corresponding text in EU regulations<sup>1</sup>

EU ref.<sup>2</sup>

lowered onto the buffers or onto supports rigidly fastened to the buffer beam in the case of the end flaps, and onto a high platform in the case of the side flaps.

No visible permanent deformation should result from the application of this load case.

For the end flaps made of aluminum alloy, additional dynamic tests might be required.

In addition to the above, the load cases and static tests shown below are also to be applied.

End Flap

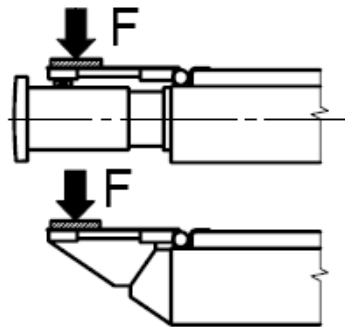

Flap dropped down onto the buffers

Flap dropped down onto supports rigidly fixed to the buffer beam

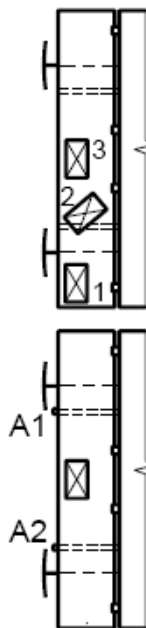

Application of a load of 65 kN at points 1.2 and then 3 over an area of 350 x 200 mm.

Flap dropped down onto 2 supports (A1 and A2) representing the two stanchions  
Application of a load of 75 kN at the centre of the flap over an area of 350 x 200 mm.

Side wall flap

|   |  |             |                                     |              |
|---|--|-------------|-------------------------------------|--------------|
|  <b>OTIF</b> | <b>ROLLING STOCK<br/>FREIGHT WAGONS – ANNEX YY</b> |             | <b>UTP WAG - YY</b><br>Page 9 of 18 |              |
|   | Status: <b>PROPOSAL</b>                            | Version: 01 | Ref.: A 94-02-YY/2.2011             | Original: EN |

OTIF UTP

Corresponding text in EU regulations<sup>1</sup>

EU ref.<sup>2</sup>

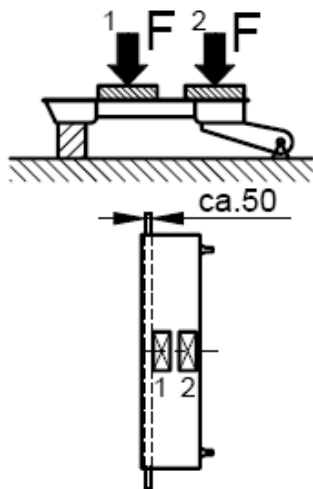

Flap dropped down into the horizontal position.

Hinges fixed by means of their pin.

Lining inserted under the entire length of the flap.

Application of loads at points 1 and then 2, of 65 kN, over an area of 350 x 200 mm.

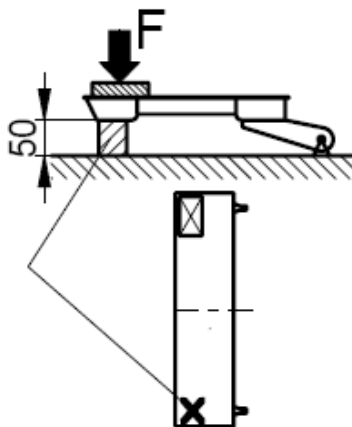

Flap dropped down into the horizontal position.

Hinges fixed by means of their pin.

- 50 mm wedge (cube) arranged under one end.

Application of 65 kN load over area of 350 x 200 mm onto the corner of the flap.

#### YY.6.2 Strength of the fixed side-wall flaps

The fixed side-wall flaps should be subjected to a force of 30 kN, applied over an area measuring about 350 x 200 mm at the edge, directed horizontally from inside the wagon towards the outside and applied at the middle of the side.

#### YY.6.3 Strength of the side stanchions

Pivoting or removable side stanchions should take the following loads:

- An outward horizontal load of 35 kN acting at 500 mm from the centre of the bore-hole (swivelling stanchion)
- An outward horizontal load of 35 kN acting at 500 mm from the upper fixation flange (removable stanchion).

#### YY.6.4 Strength of end stanchions

Each end stanchion should take an outward horizontal load of 80 kN acting at 350 mm above the top surface of the floor.

### YY.7 GRAVITY DISCHARGE WAGONS

#### YY.7.1 Strength of walls

The walls should sustain the maximum permissible loads due to the goods they are intended to carry.

|   |                                  |                         |                     |                  |
|---|----------------------------------|-------------------------|---------------------|------------------|
|  <b>OTIF</b> | <b>ROLLING STOCK</b>             |                         | <b>UTP WAG - YY</b> |                  |
|   | <b>FREIGHT WAGONS – ANNEX YY</b> |                         | Page 10 of 18       |                  |
| Status: <b>PROPOSAL</b>   | Version: 01                      | Ref.: A 94-02-YY/2.2011 | Original: EN        | Date: 11.07.2011 |

OTIF UTP

| Corresponding text in EU regulations <sup>1</sup>

EU ref. <sup>2</sup>

## YY.8 WAGONS FOR THE CONVEYANCE OF ISO CONTAINERS AND/OR SWAP-BODIES

### YY.8.1 Attachment of containers and swap-bodies

ISO containers and swap-bodies should be attached to rail vehicles using devices that engage with the load units' ISO corner castings or corner plates. Devices currently used for this purpose include spigots and twistlocks.

### YY.8.2 Strength requirements for the container/swap-body retention devices

The container/swap-body retention devices, their associated mountings and their attachment to the vehicle should be capable of withstanding the following accelerations, applied to the maximum gross container/swap-body mass. The resulting force is to be applied at the base plane of the container/swap-body when restrained by the quantity of devices indicated in the table, these being assumed to share the load evenly. The fatigue loads are to be considered acting in phase for  $10^7$  cycles, or the number of cycles corresponding to the endurance limit in the fatigue design code (if this is less).

|               | Direction         | Acceleration | Number of restraining locations |
|---------------|-------------------|--------------|---------------------------------|
| Proof Loads   | Longitudinal      | 2g           | Restrained at any 2 locations   |
|               | Transverse        | 1g           | Restrained at any 2 locations   |
|               | Vertical Downward | 2g           | Restrained at 4 locations       |
|               | Vertical Upward   | 1g           | Restrained at any 2 locations   |
| Fatigue Loads | Longitudinal      | $\pm 0,2g$   | Restrained at 4 locations       |
|               | Transverse        | $\pm 0,25g$  | Restrained at 4 locations       |
|               | Vertical          | $\pm 0,6g$   | Restrained at 4 locations       |

The spigot installation should withstand, without undergoing deformation that would render it unfit for use, an upward vertical load of 150 kN applied along the spigot centreline.

### YY.8.3 Positioning of the container/swap-body retention devices

#### Longitudinal positioning

The retention devices shall be positioned so as to be compatible with the lengths of container/swap-body that the wagon has been specified to carry. The following table lists the longitudinal distances between retention devices for different lengths of container and swap-body:

| Container/swap-body Dimension Code | Container/swap-body Length |          | Longitudinal distance between retention devices (mm) |
|------------------------------------|----------------------------|----------|--|
|                                    | mm                         | ft' in'' |  |
| 1                                  | 2991                       | 10'      | 2787 $\pm$ 2   |
| 2                                  | 6058                       | 20'      | 5853 $\pm$ 3   |
| 3                                  | 9125                       | 30'      | 8918 $\pm$ 4   |
| 4                                  | 12192                      | 40'      | 11985 $\pm$ 5  |
| A                                  | 7150                       |          | 5853 $\pm$ 3   |
| B                                  | 7315                       | 24'      | 5853 $\pm$ 3   |
| C                                  | 7420                       |          | 5853 $\pm$ 3   |
| D                                  | 7430                       | 24' 6''  | 5853 $\pm$ 3   |

|   |  |             |                                       |              |
|---|--|-------------|---------------------------------------|--------------|
|  <b>OTIF</b> | <b>ROLLING STOCK<br/>FREIGHT WAGONS – ANNEX YY</b> |             | <b>UTP WAG - YY<br/>Page 11 of 18</b> |              |
|   | Status: <b>PROPOSAL</b>                            | Version: 01 | Ref.: A 94-02-YY/2.2011               | Original: EN |

OTIF UTP

Corresponding text in EU regulations<sup>1</sup>

EU ref.<sup>2</sup>

|   |        |     |           |
|---|--------|-----|-----------|
| E | 7800   |     | 5853 ± 3  |
| F | 8100   |     | 5853 ± 3  |
| G | 12500  | 41' | 11985 ± 5 |
| H | 13106  | 43' | 11985 ± 5 |
| K | 13600  |     | 11985 ± 5 |
| L | 13716  | 45' | 11985 ± 5 |
| M | 14 630 | 48' | 11985 ± 5 |
| N | 14935  | 49' | 11985 ± 5 |
| P | 16154  |     | 11985 ± 5 |

### Lateral Positioning

#### Fixed Retention Devices

Fixed retention devices should be positioned laterally 2259±2 mm apart on the wagon.

#### Fold-down spigots

The functional dimensions (a1, a2 and C) for pairs of spigots after removal of play in the direction indicated by the arrows.

These functional dimensions should be observed when running, irrespective of the type of construction of spigots (fixed or fold-down):

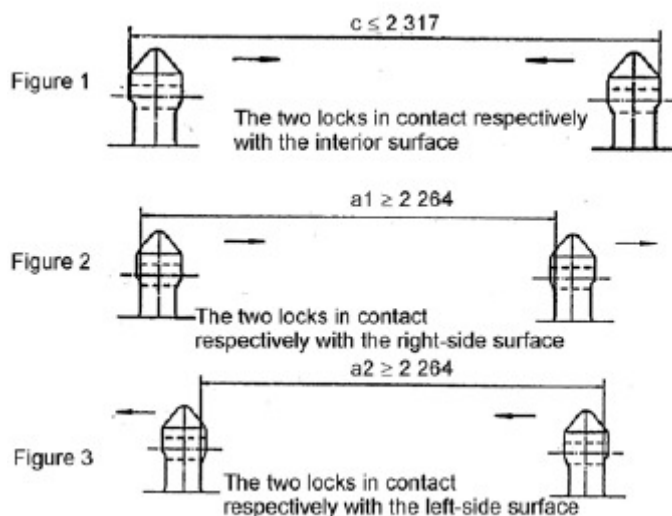

### Spigot Dimensions

The permissible operational dimensions for the spigot are as follows:

| Dimension at manufacture | Limit dimension when running             |
|--------------------------|--|
| R3                       | Maximum R15                              |
| 45°                      | Maximum 65°                              |
| 4 <sup>+0,5/0</sup> mm   | Minimum 3,5 mm                           |
| 90° <sup>0/+1,5</sup>    | Maximum 90° <sup>0/+2,0</sup> (see Note) |

Note: When exerting a lateral force on the head of the spigot in the direction of the centre of the wagon (i.e. removal of all play), the angle should be measured between the body of the spigot and a steel rule placed at right angles to the sole-bars of the opposing spigots.

The dimensions of spigots at manufacture should be as follows:



OTIF UTP

Corresponding text in EU regulations <sup>1</sup>

EU ref. <sup>2</sup>

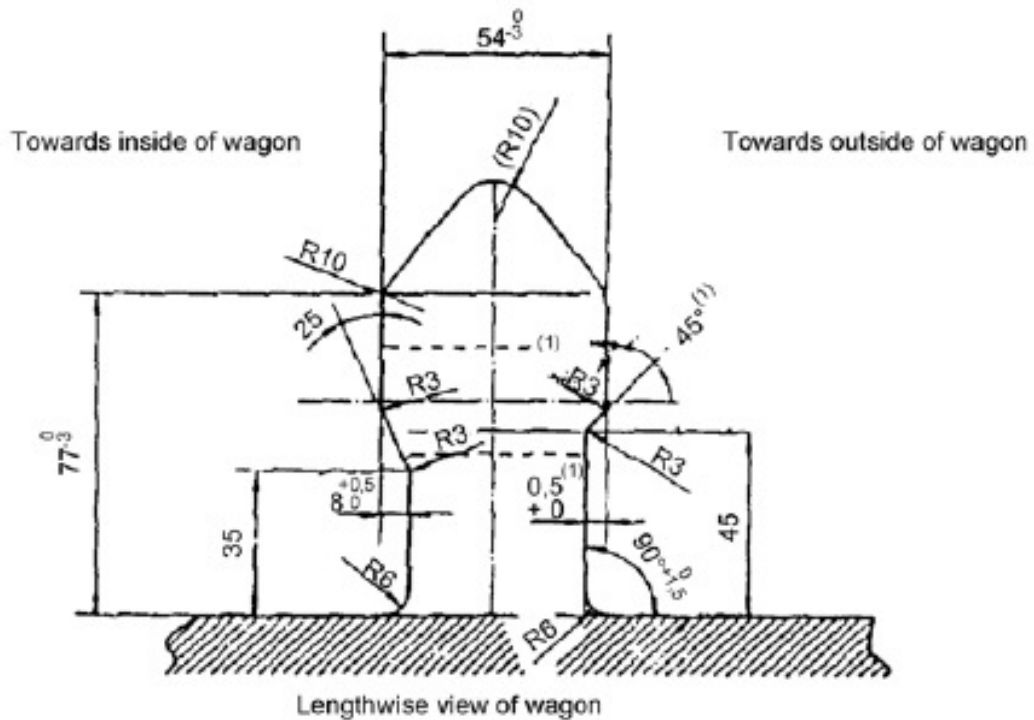

(1) Dimensions for manufacture and maximum operational dimensions resulting from wear (see point C.2)

Wagons for combined transport

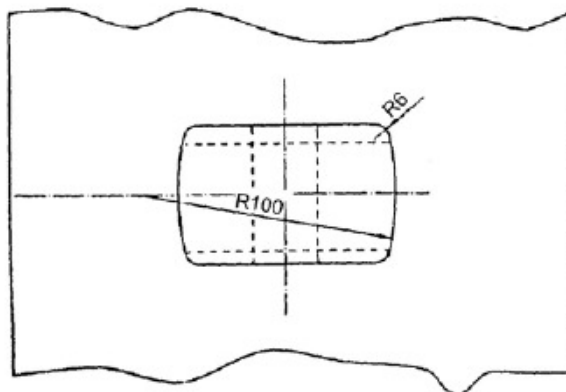
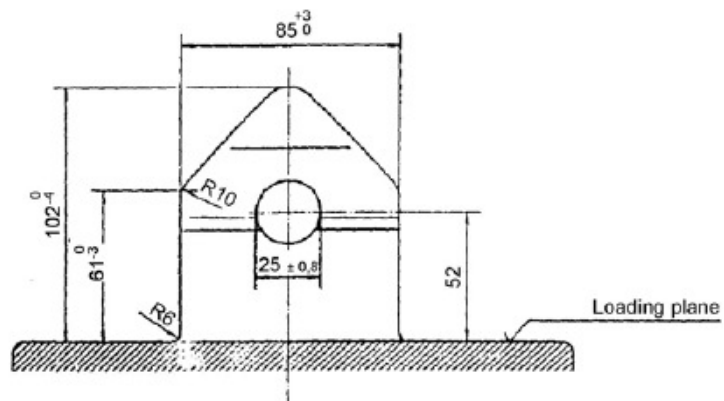

|   |  |             |                                       |              |
|---|--|-------------|---------------------------------------|--------------|
|  <b>OTIF</b> | <b>ROLLING STOCK<br/>FREIGHT WAGONS – ANNEX YY</b> |             | <b>UTP WAG - YY<br/>Page 13 of 18</b> |              |
|   | Status: <b>PROPOSAL</b>                            | Version: 01 | Ref.: A 94-02-YY/2.2011               | Original: EN |

OTIF UTP

| Corresponding text in EU regulations <sup>1</sup>

EU ref. <sup>2</sup>

## YY.9 REQUIREMENTS FOR OTHER PAYLOAD SECURING EQUIPMENT

The minimum proof strength requirements for winches, webbing straps and payload-securing rings are as follows:

Payload restraint winches for use with load restraint webbing straps should be capable of withstanding a load of 76 kN.

Payload restraint webbing straps should have a strength-rating of at least 45 kN.

Other requirements are as given in the table below as examples for a range of existing European freight wagons.

| Wagon Type and length over buffer                   | Alpha code | Type, number and position of load securing devices required  | Load case (or dimensions) for each load securing device   |
|---|------------|--|---|
| Types 1 and 3<br>Two-axle covered wagons<br>14,02 m | Gbs        | 18 hinged ring or fixed fastening bar securing devices on each side wall with 8 in the upper row (1,1 m above the floor) and 10 in the lower row (0,35 m above the floor). | Securing rings should be made from round-bar steel of at least 14 mm diameter.  |
|   |            | If wagons are fitted with securing devices located in the wagon floor then 6 should be fitted, evenly distributed along each of the side walls (12 in total).              | Should be able to withstand a tensile force of 85 kN applied at an angle of 45° to the floor surface and 30° to the longitudinal centreline of the wagon. |
| Type 2<br>Two-axle Covered wagons<br>10,58 m        | Gs         | 14 hinged ring or fixed fastening bar securing devices on each side wall with 6 in the upper row and 8 in the lower row.   | Securing rings should be made from round-bar steel of at least 14 mm diameter.  |
|   |            | If wagons are fitted with securing devices located in the wagon floor then 4 should be fitted, evenly distributed along each of the side walls (8 in total).               | Should be able to withstand a tensile force of 85 kN applied at an angle of 45° to the floor surface and 30° to the longitudinal centreline of the wagon. |
| Type 3<br>two-axle covered wagons<br>14,02 m        | Hbfs       | 18 hinged ring or fixed fastening bar securing devices on each side wall with 8 in the upper row (1,1 m above the floor) and 10 in the lower row (0,35 m above the floor). | Securing rings should be made from round-bar steel of at least 14 mm diameter.  |
|   |            | If wagons are fitted with securing devices located in the wagon floor then 4 should be fitted, evenly distributed along each of the side walls (8 in total).               | Should be able to withstand a tensile force of 85 kN applied at an angle of 45° to the floor surface and 30° to the longitudinal centreline of the wagon. |

|   |                                  |                         |                     |                  |
|---|----------------------------------|-------------------------|---------------------|------------------|
|  <b>OTIF</b> | <b>ROLLING STOCK</b>             |                         | <b>UTP WAG - YY</b> |                  |
|   | <b>FREIGHT WAGONS – ANNEX YY</b> |                         | Page 14 of 18       |                  |
| Status: <b>PROPOSAL</b>   | Version: 01                      | Ref.: A 94-02-YY/2.2011 | Original: EN        | Date: 11.07.2011 |

OTIF UTP

Corresponding text in EU regulations<sup>1</sup>EU ref.<sup>2</sup>

|  |            |  |  |
|--|------------|--|--|
| Two-axle open high-sided wagons<br>10,0 m                  | Es         | To enable sheeting or securing of the load, securing devices should be fixed to the outside of the vehicle body, 8 on each side wall.  | Should be made of round-bar steel at least 16 mm in diameter   |
| Two-axle flat wagons<br>13,86 m                            | Ks         | Fastening bars or rings for sheeting purposes. 24 on the outside of the drop sides and 8 on the outside of the drop ends.  | Should be made of round-bar steel of at least 16 mm diameter.  |
|  |            | 8 rings or fastening bars (4 per side wall) flush with the inside of the drop sides  | Should be made of round-bar steel of at least 16 mm diameter.  |
|  |            | 12 fastening devices embedded in the floor, evenly distributed along each side wall.   | Should be able to withstand a tensile force of 170 kN applied at an angle of 45° to the floor surface and 30° to the longitudinal centreline of the wagon. |
| Two-axle open high-sided/ flat composite wagons<br>13,86 m | Os         | 12 sheeting rings affixed to the outside edge of the floor along each side wall and 4 along each end wall  | Should be made of round-bar steel of at least 16mm diameter.   |
|  |            | 4 securing rings should be affixed to the same edge along each side wall.  | Should be made of round-bar steel of at least 16 mm diameter.  |
| Type 1 bogie covered wagons<br>16,52 m                     | Gas/Gass   | 16 hinged rings or fixed fastening bar i.e. 8 on each side wall. Devices should be fixed at 0,35 m above floor level and must not protrude.  | No strength requirement specified.   |
| Type 2 bogie covered wagons<br>21,7 m                      | Gabs/Gabss | 14 securing devices situated on the side walls i.e. one at each end of the side walls, one at each door upright and one in the centre of each side wall. The devices should be situated approximately 1,5 m above floor level. They must be flush with the wall. | Should be able to withstand a tensile force of 40 kN exerted in a parallel direction to the longitudinal centreline of the wagon.                          |
| Type 1 High-sided open bogie wagons<br>14,04 m             | Eas/Eaos   | 13 securing rings on each side wall fixed on the outside of the body.<br>2 securing rings on each end wall fixed on the outside of the body.   | Should be made of round-bar steel of at least 16 mm diameter.  |
| Type 2 High-sided open bogie wagons<br>15,74 m             | Eanos      | 6 securing rings on each side wall fixed on the inside of the body.<br>2 securing rings on each end wall fixed on the  | Should be able to withstand a tensile force of 40kN applied at an angle of 45° to the floor surface and 30° to the   |

|  |  |             |                                      |              |
|--|--|-------------|--------------------------------------|--------------|
|  <b>OTIF</b> | <b>ROLLING STOCK<br/>FREIGHT WAGONS – ANNEX YY</b> |             | <b>UTP WAG - YY</b><br>Page 15 of 18 |              |
|  | Status: <b>PROPOSAL</b>                            | Version: 01 | Ref.: A 94-02-YY/2.2011              | Original: EN |

OTIF UTP

Corresponding text in EU regulations<sup>1</sup>EU ref.<sup>2</sup>

|  |                  |   |  |
|--|------------------|---|--|
|  |                  | inside of the body. The devices should be spaced as regularly as possible at an approximate height of 0,2 m above floor level and must be flush with the walls when not in use. | longitudinal centreline of the wagon.  |
|  |                  | 14 securing rings on each side wall fixed on the outside of the body.<br>2 securing rings on each end wall fixed on the outside of the body.                                    | Should be made of round-bar steel of at least 16 mm diameter.  |
| Type 1<br>Flat bogie wagons<br>(without drop sides)<br>19,9 m  | Rs/Res           | 36 rings on the side solebars   | Should be made of round-bar steel of at least 16 mm diameter.  |
|  |                  | 8 rings on the outside of the drop ends   | Should be made of round-bar steel of at least 16 mm diameter.  |
|  |                  | 18 hooks on the side solebars.  | Each hook should have a cross-section at least equivalent to a diameter of 40 mm.  |
| Type 1<br>Flat bogie wagons<br>(with drop sides)<br>19,9 m     | Rns/Rens         | 36 rings on the side solebars   | Should be made of round-bar steel of at least 16 mm diameter.  |
|  |                  | 8 rings on the outside of the drop ends   | Should be made of round-bar steel of at least 16 mm diameter.  |
|  |                  | 18 fastening bars flush with the inside of the drop sides/ends  | Should be made of round-bar steel of at least 16 mm diameter.  |
|  |                  | 18 securing devices in the floor evenly distributed along the length and must not protrude above floor level when not in use.   | Should be able to withstand a tensile force of 170 kN applied at an angle of 45° to the floor surface and 30° to the longitudinal centreline of the wagon. |
| Type 2<br>Flat bogie wagons<br>(without drop-sides)<br>14,04 m | Rmms/<br>Rmmns   | 24 rings on the side solebars   | Should be made of round-bar steel of at least 16 mm diameter.  |
|  |                  | 8 rings on the outside of the drop ends   | Should be made of round-bar steel of at least 16 mm diameter.  |
|  |                  | 14 hooks on the side solebars.  | Each hook should have a cross-section at least equivalent to a diameter of 40 mm.  |
| Type 2<br>Flat bogie wagons<br>(without drop sides)<br>19,9 m  | Remms/<br>Remmns | 24 rings on the side solebars   | Should be made of round-bar steel of at least 16 mm diameter.  |
|  |                  | 8 rings on the outside of the drop ends   | Should be made of round-bar steel of at  |



OTIF UTP

Corresponding text in EU regulations<sup>1</sup>EU ref.<sup>2</sup>

|   |         |  |  |
|---|---------|--|--|
|   |         |  | least 16 mm diameter.  |
|   |         | 12 fastening bars flush with the inside of the drop sides/ends   | Should be made of round-bar steel of at least 16 mm diameter.  |
|   |         | 12 securing devices in the floor evenly distributed along the length and must not protrude above floor level when not in use.  | Should be able to withstand a tensile force of 170 kN applied at an angle of 45° to the floor surface and 30° to the longitudinal centreline of the wagon. |
| Bogie wagon with opening roof<br>14,04 m — 14,29 m            | Taems   | The wagon floor may be equipped with 6 securing devices, evenly distributed on each side of the wagon (12 in total). If such devices are fitted, then they must be flush with the floor when not in use and must meet the strength requirements specified in the adjacent column.  | Should be able to withstand a tensile force of 170 kN applied at an angle of 45° to the floor surface and 30° to the longitudinal centreline of the wagon. |
| Type 1<br>Covered bogie wagons with sliding walls<br>21,7 m   | Habiss  | It is recommended that the wagon floor be fitted with 16 securing devices. If such devices are fitted then they should be spaced at intervals of 4370mm/600mm/4200mm/1000mm/4200mm/600mm/4370mm in the longitudinal direction. In the lateral direction, the devices should be positioned 970 mm from the longitudinal centre-line of the wagon. They must not protrude above the floor when not in use. | Should be able to withstand a tensile force of 85 kN applied at an angle of 45° to the floor surface and 30° to the longitudinal centreline of the wagon.  |
| Type 2A<br>Covered bogie wagons with sliding walls<br>24,13 m | Habbins | The wagon should be provided with 16 securing devices in the floor. The fittings should be spaced at uniform intervals along each side wall. They must not protrude above the floor when not in use.   | Should be able to withstand a tensile force of 85 kN applied at an angle of 45° to the floor surface and 30° to the longitudinal centreline of the wagon.  |
|   |         | Each end wall of the wagon should be provided with 4 securing fittings, arranged in sets of 2 near each corner upright inside the wagon at heights of about 0,75 and 1,5 m above the   | Should be able to withstand a tensile force of 30kN in all directions when this force is exerted simultaneously on two fittings at the same height.        |



OTIF UTP

Corresponding text in EU regulations<sup>1</sup>EU ref.<sup>2</sup>

|   |              | floor   |   |
|---|--------------|---|---|
| Two-axle covered wagons with sliding walls Types 1A and 2A 14,2 m and 15,5 m respectively   | Hbins/Hbbins | Wagon should be provided with 12 load securing fixings in the floor. They must be positioned at uniform intervals along each side. They must not protrude above the floor when not in use.  | Should be able to withstand a tensile force of 85 kN applied at an angle of 45° to the floor surface and 30° to the longitudinal centreline of the wagon.                           |
|   |              | Each end wall of the wagon should be provided with 4 securing fittings, arranged in sets of 2 near each corner upright inside the wagon at heights of about 0,75 and 1,5 m above the floor. These fittings must not protrude from the wall when not in use. | Should be able to withstand a tensile force of 30 kN in all directions when this force is exerted simultaneously on two fittings at the same height.                                |
| Bogie flat wagons fitted with a mechanical sheeting system, 19,9 m and 20,09 m respectively | Rils/Rilns   | It is recommended that 10 retractable securing rings be fitted. The securing rings should be evenly distributed in the longitudinal direction and should be flush with the floor when not in use.   | Should be able to withstand a tensile force of 170 kN applied at an angle of 45° to the floor surface and an angle of 30° with the vertical plane of the wagon's longitudinal axis. |
|   |              | It is recommended that 4 securing rings be fitted on the inner surfaces of the end walls.   | No strength requirement specified   |
| Flat wagons with 2 three-axle bogies 16,4 m   | Sammns       | 26 round steel rings should be fixed to the solebars  | Should be made of round-bar steel of at least 16 mm diameter.   |
|   |              | 12 securing rings should be fixed to the floor and they should be evenly distributed along each side of the wagon and should be flush with the floor when not in use.   | Should be able to withstand a tensile force of 170 kN applied at an angle of 45° to the floor surface and an angle of 30° with the vertical plane of the wagon's longitudinal axis. |

|   |  |             |                                       |              |
|---|--|-------------|---------------------------------------|--------------|
|  <b>OTIF</b> | <b>ROLLING STOCK<br/>FREIGHT WAGONS – ANNEX YY</b> |             | <b>UTP WAG - YY<br/>Page 18 of 18</b> |              |
|   | Status: <b>PROPOSAL</b>                            | Version: 01 | Ref.: A 94-02-YY/2.2011               | Original: EN |

OTIF UTP

| Corresponding text in EU regulations <sup>1</sup>

EU ref. <sup>2</sup>

## YY.10 DEPOT TOW HOOKS

Where fitted, tow hooks shall conform with the following requirements :

| Wagon feature   | Number of Hooks  | Location of Hooks          |
|---|------------------|----------------------------|
| One or two gangways or end platforms, and underframe width $\leq$ 2 500mm | One on each side | Free                       |
| General case  | One on each side | In the middle of the wagon |
| Design making it impossible to fit one hook in the middle of the wagon    | Two on each side | Near the corners           |

The hook and its fastening to the underframe shall be strong enough to allow a rake with a total mass of 240 t, to be towed with a single hook, with the pull exerted outward at an angle of 30 degrees in relation to the centreline of the track. To achieve this, the hook shall be designed to carry a tractive force of 50 kN.

Notes:

1. The tow hook shall be positioned such that there is no danger of damaging the steps, coupler control levers and brake control handles by the towing cable.
2. The tow hook shall be positioned so as to avoid any risk of a shunter's clothing (particularly trouser legs) becoming caught when climbing on or off a step.
3. To reduce the potential danger to staff at the side of the train no parts of tow hooks shall protrude by more than 250 mm beyond the wagon underframe or body. Where parts of the hook protrude by between 150 mm and 250 mm beyond the wagon underframe or body, the hook and its support shall be painted yellow.